

Terms and Conditions of Network Participation

FOR MEMBER SCHOOLS INSTALLED PRIOR TO 2008



Notice to Current Members regarding the attached Terms and Conditions of Network Participation:

- All references to "Channel One Communications Corp (COCC)" now refers to Channel One, LLC. Channel One is under new ownership.
- All references to "Channel One News VCR", "General Use VCR", and "Equipment" now refers to "Digital Recorder Head-end" as Channel One is upgrading to new digital technology in the 2007/2008 school year.

Terms and Conditions of Network Participation

FOR MEMBER SCHOOLS INSTALLED PRIOR TO 2008

General Terms

This sets forth the general terms of the School Agreement (the "Agreement") under which the School will participate in the Educational Network (the "Network") of Channel One Communications Corporation ("COCC") for a period of three full school years, plus the partial school year in which installation occurs, (the "Initial Term"), subject to the extension (the "Renewal Term") as hereinafter set forth. These General Terms form part of the School Agreement between the School and COCC.

A. Introduction

COCC will provide to the School the following educational programming and equipment services, which comprise the network, without any charge or fee subject to the responsibilities of the School outlined in this Agreement.

Channel One News—A daily 12-minute newscast specifically designed by COCC for middle school and high school students, which will include up to two minutes of commercial content.

Channel One Connection—Instructional support programming selected by an independent board or organization.

Equipment—A satellite transmission receiving system to receive the Network's programs, two central/addressable recording-playback VCRs, one dedicated to Channel One News (the "Channel One News VCR") and the other used for the Channel One Connection and other school purposes (the "General Use VCR"), television sets in certain classrooms and a preview monitor (all these items together known as the "Equipment"), and the wiring to connect the Equipment and create an intra-school television system.

The Equipment, described in Exhibits A and B attached hereto, subject to revision from time to time at COCC's reasonable discretion, remains the property of COCC but is available for general use by the School in addition to reception of the Network's programming.

B. COCC Undertakings

- 1) COCC will provide television sets with screens of at least 19" for the School's classrooms, not to exceed one set for each 23 students, plus one television set for program preview (the "monitor"), one fixed position satellite dish, two central/addressable VCRs housed in a "headend unit" and the necessary wiring, all as described in Exhibit A. The School may elect not to have certain classrooms installed in order to accommodate (1) teachers who do not wish to show Channel One News and/or (2) students who do not wish to view or whose parents do not wish them to view Channel One News. The number of television sets to be installed must be mutually agreeable to COCC and the School.
- 2) COCC will install the television sets in the classrooms in locations mutually agreeable to COCC and the School, generally in accordance with the Network system overview attached as Exhibit B. The monitor, VCRs and other headend equipment will be situated within 150 cable feet of the satellite dish. COCC will purchase all Equipment, install it at no cost to the School and repair any areas damaged during installation on a "patch to match" basis.

- 3) COCC will transmit Channel One News on a minimum of 180 days per year. The actual transmission dates will be selected to provide Channel One News on the days on which the largest numbers of schools nationwide are open.
- 4) COCC will transmit Channel One News to the School, where it will automatically be recorded on the Channel One News VCR, not later than 6:00 a.m. on each day of transmission, so that the School will have time to preview the newscast and determine whether or not it wishes to show Channel One News that day.
- 5) Each Channel One News broadcast will run for approximately twelve minutes and will include not more than two minutes of commercial content. The editorial content will include current events and news material of an educational nature intended to be of interest to middle school and high school students. The commercial content will be limited to materials suitable for such students and will be within the standards and guidelines attached as Exhibit C.
- 6) COCC will arrange for an independent board or organization (the "Board") to select instructional support programming to be transmitted on the Channel One Connection. COCC will provide the Board with up to \$500,000 each school year to cover costs related to the purchase of usage rights for such programming. In addition, COCC will provide up to 1,000 hours of satellite time each school year for transmission of the programming selected by the Board. Programming for the Channel One Connection will be transmitted in accordance with the schedule to be periodically provided to the School and will be automatically recorded on the General Use VCR provided the School has inserted a videotape in the VCR.
- 7) COCC will provide the School with periodic guides for Channel One News and periodic bulletins advising of special events to assist educators in using the Network to enhance the educational process.
- 8) COCC will train the equipment operator(s) designated by the School to operate the Network's in-school Equipment.
- 9) COCC will provide all reasonable maintenance and service for the Equipment. COCC may from time to time exchange or replace any Equipment with equipment of comparable function. COCC may remove any Equipment from the School which is not being used for its intended purpose.
- 10) COCC will obtain advice from three advisory groups with regard to the Network: nationally known leaders from education, business and government to provide on-going counsel and advice regarding the Network and its various services; a cross-section of educators from different subject specialties, geographic regions and ethnic origin to review and provide advice regarding Channel One News programming and Network guides; and teachers and parents to review the advertisements which run on Channel One News.
- 11) COCC will not include the School in its automated audit program without the School's prior consent. COCC plans to audit a total of five television sets in each of 280 schools. Selected schools will be contacted prior to installation and asked on a voluntary basis to accept these five television sets which will passively record:
 - a) The time of day Channel One News is shown.
 - b) The length of the Channel One News broadcast.
 - c) The volume of the broadcast.
- 12) COCC will provide a toll-free number to the School so that the School can easily provide suggestions, feedback and constructive criticism to COCC regarding the Network's programming as well as report any problems with the Equipment.

C. School Undertakings

- 1) The School agrees to permit COCC to install, maintain and service the Equipment by providing access to the School from 3:00 p.m. to 12:00 a.m. while School is in session and from 8:00 a.m. to 5:00 p.m. when School is not in session.
- 2) The School agrees to provide a floor plan/blueprint of the School, on which the locations for the television sets will be indicated. This Agreement will not be binding upon COCC without the attached floor plan/blueprint.
- 3) Locations for the headend unit and all television sets must be within 12 feet of AC electrical power outlets. If electrical power outlets are not available within 12 feet, the School must provide new electrical power outlets before installation. The headend unit must be situated within 150 cable feet of the satellite dish.
- 4) The School agrees to receive the Channel One News programs from COCC and to show the entire daily newscast on all installed television sets.

The School will show Channel One News at a time or times of its choosing, provided that (1) Channel One News must be shown on at least 90% of the days that school is in session and Channel One News is broadcast, (2) Channel One News must be shown when students are present in a homeroom or classroom (i.e. not before school, after school or during lunch) and (3) if Channel One News is not shown at a single time, it will be shown in accordance with the viewing schedule as described on the School Agreement.

- 5) The School may copy any program transmitted on the Network for any educational purpose of the School (unless otherwise indicated in the schedules provided or as part of the transmission because of contractual limitations), but will not without COCC's prior written consent in each instance permit others to use any copies for any purpose.
- 6) The School agrees to provide at least one designated equipment operator at all times to operate this Equipment.
- 7) The School agrees to notify COCC within 48 hours of any malfunction or other problem with the Equipment and to take reasonable precautions to protect the Equipment from vandalism, tampering, theft, fire and other hazards. The School will not be liable to COCC for such damaged or stolen equipment. COCC may, but is not required to, repair or replace such damaged or stolen equipment.
- 8) The School may add additional equipment to the Network at the School's expense so long as such additional equipment does not interfere with the reception and viewing of the Network, as determined by COCC.
- 9) The School agrees to maintain reasonable records showing its compliance with its Agreement with COCC and will permit COCC reasonable access to its premises, students, teachers and enrollment records by grade to monitor such compliance.
- 10) The School is responsible for obtaining zoning and building permits or waivers when required. This Agreement is not binding on COCC unless the School furnishes the required zoning and building permits or waivers or satisfactory evidence that the permits or waivers are not required within 15 days after completion of the site survey.
- 11) The School acknowledges that the coaxial cable used in installation may be exposed in some places and will not be covered by COCC. The cable may be covered and the installation hardware may be aesthetically improved by the School at the School's expense so long as such covering and improvement do not interfere with the viewing and reception of the Network.
- 12) The School agrees to make available a site survey contact familiar with the school property and authorized by the principal to participate in the site survey required to develop the installation plan. Such a survey typically takes from four to eight hours, depending upon the size of the school. The School further agrees to make available the principal to approve the installation plan at the completion of the site survey. After approval, the installation plan cannot be altered without mutual agreement of COCC and the School.
- 13) The School acknowledges that if during the site survey or installation COCC encounters asbestos in the School which interferes with installation, either the School or COCC may terminate this Agreement. The School further acknowledges that the School must identify during the site survey any areas where asbestos may exist.
- 14) So long as Channel One News is shown by the School in accordance with the provisions of this Agreement, the School may use the equipment for other educational or other purposes, provided that the Equipment may not be used by the School to show any other news program, specifically designed for viewing by students in schools and which contains advertising, without the prior written approval of COCC.

D. General

- 1) To qualify for the Network, a school must have at least 300 students in grades six through twelve (the "Qualified Students"). The School represents that it qualifies and will continue to qualify for the Network in accordance with these standards.
- 2) The School will participate in the Network for the Initial Term and any Renewal Term(s). The School Agreement will be automatically extended for successive three-school-year Renewal Terms without change of Equipment, unless the School or COCC notifies the other to the contrary more than three months prior to the end of the Initial Term of this Agreement or any Renewal Term of this Agreement.
- 3) This Agreement does not require that all teachers use Channel One News or that all students or any particular student view Channel One News. The School may at its discretion develop appropriate procedures to accommodate students who do not wish to view Channel One News or whose parents do not wish them to view Channel One News.
- 4) COCC will have no obligation to provide the Network to the School unless COCC is providing the Network to high schools and middle schools in the United States.
- 5) The School agrees to notify COCC if and when it does not show a Channel One News broadcast and to advise COCC why it has declined to show a particular newscast so that COCC may determine if problems in the editorial or advertising content need to be addressed. If the School does not consistently show Channel One News (i.e., on at least 90% of the days the School is in session and Channel One News is transmitted), then COCC may terminate this Agreement. COCC agrees to use its reasonable best efforts to address the reasons why the School is not showing Channel One News prior to exercising COCC's right to terminate this Agreement under this Paragraph D5.
- 6) COCC may terminate this Agreement upon the occurrence of any of the following events: (i) if the School breaches its obligations under this Agreement; (ii) if the number of Qualified Students in the School declines at any time during any three-year term of this Agreement from the number of Qualified Students at the beginning of the three-year term by more than 25% or falls below 300; (iii) if the satellite dish or any component of the receiving system or headend equipment is damaged, destroyed or stolen; (iv) if COCC determines in its reasonable discretion that the number of television sets damaged, destroyed or stolen at the School is excessive; (v) if participation by the School in the Network violates any law, ordinance or regulation; (vi) if COCC determines in its sole discretion that installing the School is not economically justifiable to COCC; (vii) if COCC ceases to provide the Network to other high schools or middle schools in the United States; or (viii) if the School shows Channel One News on fewer than 90% of the days on which the School is in session and Channel One News is transmitted.
- 7) Upon termination of this Agreement, COCC shall have the right but not the obligation to remove the Equipment from the School at COCC's expense. COCC will not be required to remove any wiring.
- 8) This Agreement will be automatically extended for successive three-year Renewal Terms without change of Equipment, unless the School or COCC notifies the other to the contrary more than three months prior to the end of the Initial Term of this Agreement or any Renewal Term of this Agreement.
- 9) This Agreement may not be modified or amended except by a written instrument executed by or on behalf of each of the parties. No delay or omission on the part of any party in exercising any right or privilege under this Agreement will operate as a waiver thereof, nor will any waiver on the part of either party of any right or privilege under this Agreement operate as a waiver of any other right or privilege under this Agreement nor will any single or partial exercise of any right or privilege preclude any other or further exercise thereof or the exercise of any other right or privilege under this Agreement.
- 10) The terms of this Agreement shall be binding upon and inure to the benefit of COCC, the School and their respective successors and assigns. COCC may assign this Agreement but such assignment shall not relieve COCC of its obligations hereunder.

Exhibit A: The Channel One Network Equipment Chart Code

- A. External: On the roof will be a 1.2 meter (1.8 meter in a few sections of the U.S.) aluminum satellite dish (A) mounted with a non-penetrating roof mount with a suitable LNB (low noise block down converter) for the reception of the satellite signal.
- B. Internal: The received signal will pass through coaxial cable to the headend equipment located within 150 feet of the dish. The headend unit consists of three pieces of equipment housed in a locked tabletop cabinet (B) and one accessible VCR. The pieces of housed equipment are:
 - C. The receiver/controller/IR interface/pilot generator/Channel One News switch (C) which tunes to and locks the system on the proper satellite transponder and receives/converts the satellite signal; it also controls, via automatic remote infrared signals, the two central/addressable VCRs; and contains the on/off control switch for the school's television network. The preview switch for viewing Channel One News prior to the system distribution is also located on the receiver/controller.
 - D. The Channel One News VCR (D) that contains the tape on which the daily program is recorded prior to 6:00 a.m. This VCR is locked into the cabinet and is only serviced/used by a COCC designated technician.
 - E. Modulator (E) which places the Channel One News signal on the proper station for the School's viewing. It also amplifies the signal's output level to guarantee the highest quality signal.
- F,G. Also within this cabinet will be the local inputs (F) for the school's VCR, video disc player, video camera, TV antenna, local cable, additional rotatable satellite antenna, etc., if the school decides to provide those functions and equipment, and amplifiers (G), if necessary, to assure sufficient signal level at each television set in the system.
- H. An additional VCR (H) will be provided which is accessible by school personnel. This VCR will house the tape on which the Channel One Connection programs will be automatically recorded if the proper tape is in place.
 - I. The signal will pass through coaxial cable to the television sets in the classrooms. The television sets (I) will be custom designed 19" color units that will contain the necessary mechanism to be automatically controlled from the headend. The television sets will be mounted to the wall or ceiling.
 - J. Also included is an RF input jack (J) in each classroom for easy access by the teacher to simply plug in a VCR, video camera, etc., provided by the school for viewing on the classroom's television set.
 - K. The preview monitor will be a color television set.

Exhibit B: The Channel One Network Equipment Chart

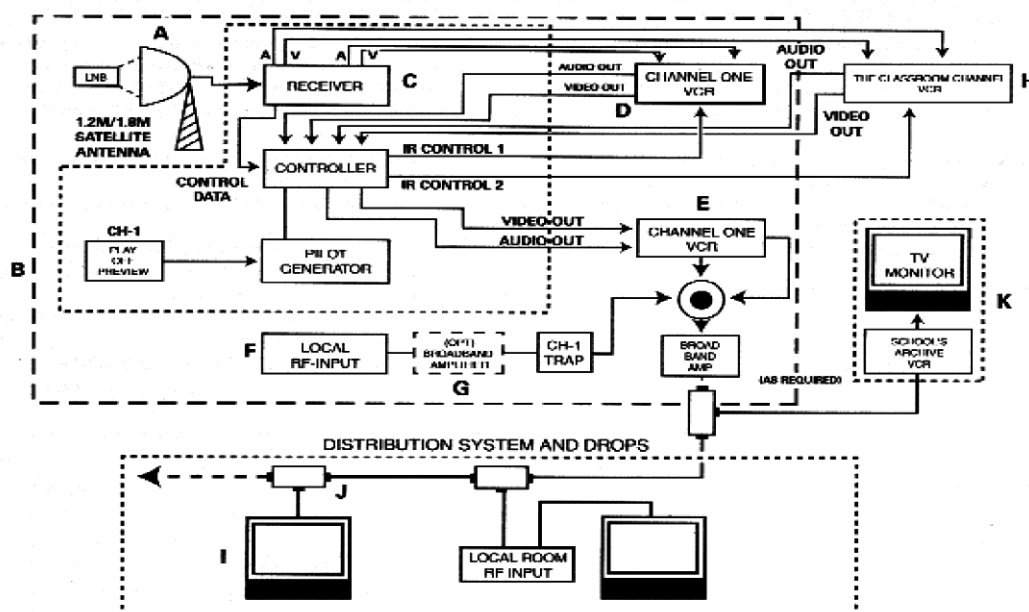

Exhibit C: Channel One Network System Overview

THE CHANNEL ONE NETWORK EQUIPMENT STANDARDS AND GUIDELINES TO GOVERN THE ADVERTISING THAT WILL APPEAR IN COCC PROGRAMMING.

1) Policy Statement

It is the policy of COCC to present advertising which is truthful and tasteful and not misleading or deceptive. COCC recognizes that it has a special responsibility to its middle school and high school audience because of its age and the educational environment in which the programming is viewed. Careful attention will be given to all guidelines to assure that practices and behavior that are inconsistent with the learning environment, as well as the community at large, will be avoided in commercial programming. Additionally, strict separation of advertising messages and editorial content will be maintained.

2) Products and/or Services that Will Not Be Considered for COCC Programming

- A. Abortion clinics
- B. Alcoholic beverages (including beer, wine and distilled spirits)
- C. Contraceptive products
- D. Firearms, ammunition and fireworks
- E. Gambling
- F. "Head Shops" or other establishments whose activity concentrates on drug related paraphernalia
- G. Lotteries
- H. Motion pictures rated "R", "NC17" or "X" by the Motion Picture Association of America
- I. Prescription drugs
- J. Tampons or other feminine hygiene products
- K. Political advertisements
- L. Religious time
- M. Solicitation of funds
- N. Tobacco products (including cigarettes, cigars, pipe tobacco and "smokeless tobacco")

3) General Guidelines

COCC reserves the right to accept or reject at any time advertising for any product or service submitted for airing over its facilities. The following general guidelines will be developed to aid sponsors in the development of appropriate advertising:

- A. Advertising/Programming Distinction: Any creative technique that may confuse the viewer by blurring the distinction between programs and commercials is unacceptable.
- B. Audio/Visual Misrepresentation: Advertisements will avoid audio and video techniques that in any way misrepresent, distort, exaggerate or over-glamorize their attributes or functions.
- C. Community Sensibilities: Advertising which belittles any group or person based on social, racial, ethnic or religious traits or because of age, gender or disability is unacceptable.

- D. Comparative Advertising: Comparative advertising may not distort or exaggerate differences between competitive products or services or otherwise create a false, deceptive or misleading impression.
- E. Controversial Issues: Advertising which takes a position on a controversial issue of public importance is unacceptable. A controversial issue of public importance is defined as one which involves matters having significant impact on society or its institutions and as to which there is a current public debate with substantial segments of the community taking opposing positions.
- F. Criminal Activity: Advertising which promotes or accepts violence, crime or obscenity is unacceptable. Advertising may not contain the portrayal of specific detailed techniques involved in the commission of crimes, the use of weapons, the avoidance of detection, nor any other forms of anti-social behavior.
- G. Dramatizations, Reenactments and Simulations: A commercial which utilizes a dramatization, reenactment or simulation must accurately depict the product, service or event involved.
- H. Endorsements: Endorsements must reflect the honest opinions, beliefs, findings or experience of the endorser. Endorsements may not contain any claims that could not be substantiated if made directly by the advertiser.
- I. Safety: Advertisements and products advertised must be consistent with generally recognized safety standards. All advertising that disregards normal safety precautions is unacceptable.
- J. Subliminal Perception: Any advertising utilizing the technique of "subliminal perception" or any similar technique is unacceptable.

4) Development of Audience Specific Advertising

Although the ultimate responsibility of developing advertising rests with the individual sponsors, COCC will encourage the development of specific messages that accomplish the following objectives:

- A. Include a balanced representation of individuals from a variety of social, racial, ethnic or gender groups.
- B. Provide positive role models for all members of the viewing audience.
- C. Include and portray individuals with physical and mental impairments.
- D. Place an emphasis on the importance of education and remaining in school.
- E. Communicate strong messages against all forms of anti-social behavior, including drug use, violence, prejudice, etc.